

Driver de led DMX PWM 6X6A



LX-2108B-M6-5



70060055

Important: Read All Instructions Prior to Installation

Function introduction

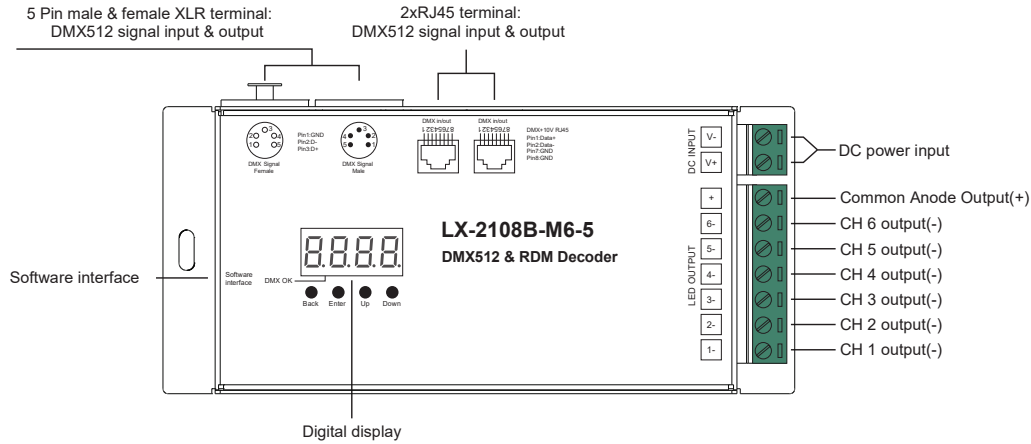

Product Data

Input Voltage	Output Current	Output Power	Remarks	Size(LxWxH)
12-24VDC	6x6A	6x(72-144)W	Constant voltage	187.7x85.3x41mm

- Master & decoder mode, RDM function
- Metal housing, digital display to show data directly, easily to set and show DMX address.
- With multiple kinds of DMX in/out ports: RJ 45, XLR, normal screws.
- Total 6 PWM output channels, common anode. DMX channel quantity 1CH or 6CH settable
- PWM output resolution ratio 8bit, 16bit settable.
- Output PWM frequency from 500Hz ~ 35KHz settable.
- Output dimming curve gamma value from 0.1 ~ 9.9 settable.
- Decoding mode settable.
- Galvanic isolation

Safety & Warnings

- DO NOT install with power applied to device.
- DO NOT expose the device to moisture.

Operation

Before you do other settings, please set the device to be Master or Decoder mode.

run1 = DMX Decoder mode, run2 = DMX Master mode(stand alone).

Keep on clicking Down button, to get run1 or run2, then click Enter, then click Down button to choose 1 or 2, then click Back button.



I. For run2 DMX Master mode: After power on the device, if keep on clicking Up button, you will find below menu on display:

8.8.8.8 Means brightness for each output PWM channel. First 1 means PWM output channel 1 and it is selectable from 1 to 6 by clicking "UP" or "Down" button. Second 01 means brightness level, click "Enter" button, the display flashes, then click "UP" or "Down" button to select from 00-99-FL, which means 0%-99%-100% brightness, then click "Back" button to confirm.

8.8.8.8 means chasing effects, total 4 effects selectable from 01-04. Click "Up" or "Down" button to select the menu, then click "Enter" button to enter into the effect, then click "Up" or "Down" button to select from 01-04.

CA01: Fade-up (0%-100%) and fade-down (100%-0%) of output 1, then output 2, output 3,, output 5, output 6, then simultaneously fade-up and fade-down of output 1, 2, 3, 4, 5, 6, then fade-up and down of output 1,, cycling chase

CA02: Fade-up (0%-100%) of output 1, then simultaneous fade-down (100%-0%) of output 1 and fade-up (0%-100%) of output 2, simultaneous down of output 2 and up of output 3,, simultaneous down of output 4 and up of output 5, simultaneous down of output 5 and up of output 6, simultaneous down of output 6 and up of output 1, then up of output 1,, cycling chase

CA03: Fade-up (0%-100%) of output 1, then output 2, output 3,, output 5, output 6, then simultaneously fade-up of output 1, output 2, output 3, output 4, output 5 and output 6, then fade up of output 1,, cycling chase

CA04: Fade-down (100%-0%) of output 1, then output 2, output 3,, output 5, output 6, then simultaneously fade-down of output 1, output 2, output 3, output 4, output 5, output 6, then fade-down of output 1,, cycling chase

8.8.8.8 means chasing speed, it is selectable from 01-09, 01 is the slowest, 09 is the fastest.

II. For run1 DMX decoder mode: After select run1, if keep on clicking Up button, you will find below menu on display:

8.XXX DMX signal indicator : When DMX signal input is detected, the indicator on the display following after 8 turns on red, the indicator will turn off and the character 8 will flash if no DMX input detected.

8.XXX Means DMX address. factory default setting is 001.

88XX Means DMX channels quantity. factory default setting is CH06

88XX Means Bit (8bit or 16bit). factory default setting is 16bit

88XX Means output PWM frequency. factory default setting is 1K HZ

88XX Means output dimming curve gamma value, factory default setting is ga 1.5

88XX Means Decoding mode, factory default setting is dp1.1

By pressing and holding button Back + Enter together at the same time over 5 seconds until the display go off, it will restore to default settings .

Wiring diagram

1.Work as Master mode

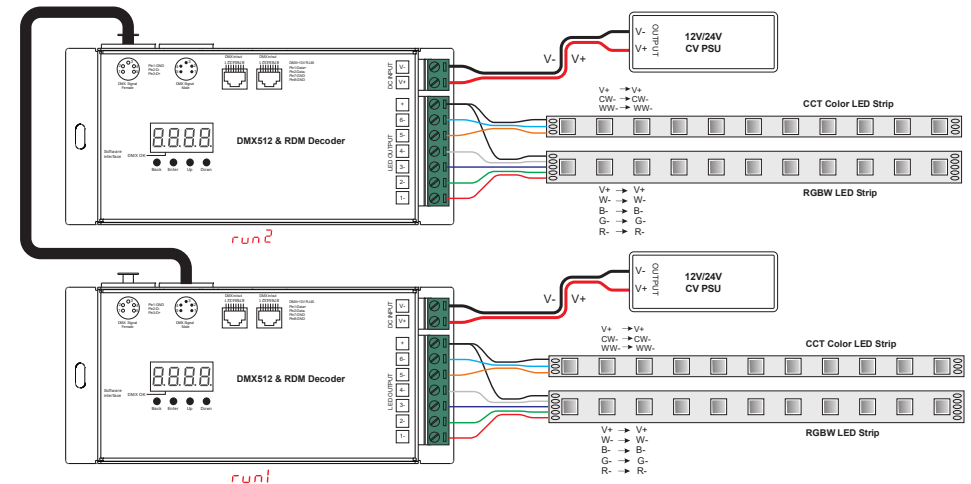

2. Work as Decoder mode

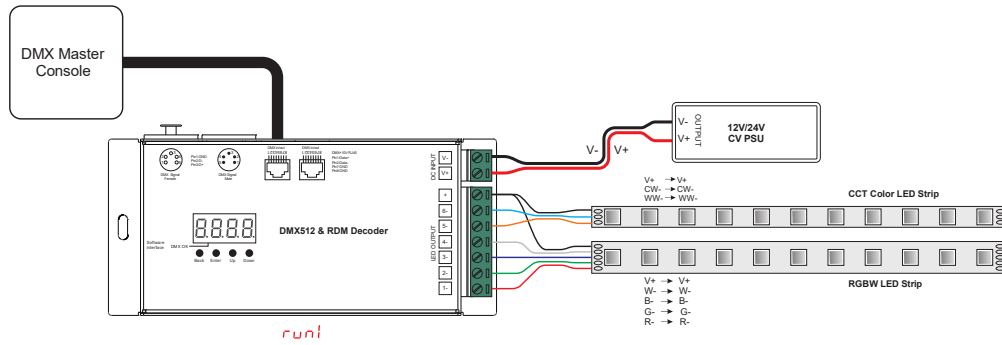

1. DMX address setting (Factory default is A001, address 001) :

select menu **8 XXX**, click button "Enter", display flashes, then click or hold button "Up" / "Down" to set DMX address (click is slow, hold is fast.), then click button "Back" to confirm.

2. DMX channel quantity setting (Factory default is CH06, 6 channels) :

Select menu **88 XX**, click button "Enter", display flashes, then click button "Up" / "Down" to set DMX channel quantity, then click button "Back" to confirm.

For example the DMX address is already set 001.

CH01=1 DMX address for all the output channels, which are all address 001.

CH06=6 DMX addresses, output 1, 2, 3, 4, 5, 6 is address 001, 002, 003, 004, 005, 006.

3. PWM output resolution Bit setting (Factory default is bt16, 16 bit) :

select menu **88 XX** click button "Enter", display flashes, then click button "Up" / "Down" to choose 08 or 16 bit, then click button "Back" to confirm.

4. output PWM frequency setting (Factory default is PF01, 1kHz) :

select menu **88 XX** click button "Enter", display flashes, then click button "Up" / "Down" to choose 00~35, then click button "Back" to confirm. 00=500HZ, 01=1kHz, 02=2kHz.....25=25kHz, 35=35kHz.

5. output dimming curve gamma value setting (Factory default is gA1.5) :

select menu **88 XX** click button "Enter", display flashes, then click or hold button "Up" / "Down" to choose 0.1~9.9, then click button "Back" to confirm.

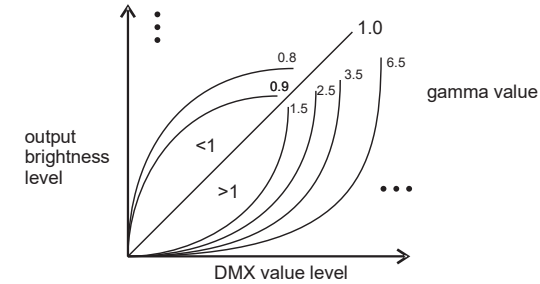

6. DMX decoding mode setting (Factory default is dp1.1) :

Select menu **88 XX**, click button "Enter", display flashes, then click or hold button "Up" / "Down" to choose the decoding mode, then click button "Back" to confirm. "dPxx" means the DMX address quantity used for control of corresponding PWM output channel quantity. 1st "x" is DMX address quantity, 2nd "x" is PWM channel quantity.

Fine dimming: the fine dimming effect can only be visible when the dimming curve gamma value is set lower than 1.4, and the lower the value is, the more visible the fine dimming effect will be.

DMX address is 001, CH01

DMX Console Slider number	dp1.1	dp2.1
DMX channel		
1	for all outputs dimming	for all outputs dimming
2	No use	for all outputs fine dimming

DMX address is 001, CH06

DMX Console Slider number	dp1.1	dp7.1	dpA.1	dpA.2	dpA.3	dpA.4	dpA.6
DMX channel							
1	for output 1 dimming	for output 1 dimming	for output 1 dimming	for output 1 dimming	for output 1 dimming	for output 1 dimming	for outputs 1+2 color tuning
2	for output 2 dimming	for output 2 dimming	for output 2 dimming	for output 2 dimming	for output 2 dimming	for output 2 dimming	for outputs 1&2 master dimming
3	for output 3 dimming	for output 3 dimming	for output 3 dimming	for outputs 1&2 master dimming	for output 3 dimming	for output 3 dimming	for outputs 3+4 color tuning
4	for output 4 dimming	for output 4 dimming	for output 4 dimming	for output 3 dimming	for outputs 1&3 master dimming	for output 4 dimming	for outputs 3&4 master dimming
5	for output 5 dimming	for output 5 dimming	for output 5 dimming	for output 4 dimming	for output 4 dimming	for outputs 1&4 master dimming	for outputs 5+6 color tuning
6	for output 6 dimming	for output 6 dimming	for output 6 dimming	for outputs 3&4 master dimming	for output 5 dimming	for output 5 dimming	for outputs 5&6 master dimming
7		for all outputs master dimming	for all outputs master dimming	for output 5 dimming	for output 6 dimming	for output 6 dimming	No use
8			strobe effects	for output 6 dimming	for outputs 4&6 master dimming	for outputs 5&6 master dimming	No use
9			No use	for outputs 5&6 master dimming	strobe effects	No use	No use
10			No use	No use	No use	No use	No use

Assign DMX address through RDM

When using RDM to assign DMX address to the device, the digital display will flash and the connected lights will also flash at the same frequency. Once the display stops flashing, the connected light also stops flashing.

The data definitions for strobe channel are as follows:

```
{0, 7},//undefined
{8, 65},//slow strobe-->fast strobe
{66, 71},//undefined
{72, 127},//slow push fast close
{128, 133},//undefined
{134, 189},//slow close fast push
{190, 195},//undefined
{196, 250},//random strobe
{251, 255},//undefined
```

The supported RDM PIDs are as follows:

```
DISC_UNIQUE_BRANCH
DISC_MUTE
DISC_UN_MUTE
DEVICE_INFO
DMX_START_ADDRESS
IDENTIFY_DEVICE
SOFTWARE_VERSION_LABEL
DMX_PERSONALITY
DMX_PERSONALITY_DESCRIPTION
SLOT_INFO
SLOT_DESCRIPTION
MANUFACTURER_LABEL
SUPPORTED_PARAMETERS
```

Restore to Factory Default Setting

Press and hold down both " Back " and "Enter" keys until the digital display turns off, then release the keys, system will reset and the digital display will turn on again, all settings will be restored to factory default.

Default settings are as follows:

```
DMX Address Code: a001
DMX Address Quantity: SW1=0: ch06, SW1=1: ch01
PWM Resolution Mode: bt16
PWM frequency: F010
Gamma: ga1.5
Decoding Mode: dp1.1
```